



MC442

High Performance Microstepping Driver



Shenzhen xinlichuan electric co.,ltd.

**Add: Area B,Floor 8, Block20 , Guang Qian Industrial Zone ,
No.3 Long Zhu Road,Nanshan District,Shen Zhen,Guang Dong,China**

CATALOG

1. Introduction.....	1
◆ Introduction.....	1
◆ Features.....	1
◆ Applications.....	1
2. Specifications.....	2
◆ Electrical Specifications	2
◆ Operating Environment.....	2
◆ Installation specifications	2
◆ Elimination of Heat.....	2
3. External terminal instructions.....	2
◆ Control Signal Connector.....	2
◆ Main Circuit Connector.....	3
4. Control Signal Connector Interface.....	3
◆ Typical Connection.....	4
◆ Sequence Chart of Control Signals.....	4
5. Connecting the Motor.....	4
◆ Connections to 4-lead Motors.....	4
◆ Connections to 8-lead Motors.....	5
6. Power Supply Selection.....	5
◆ Regulated or Unregulated Power Supply.....	5
◆ Multiple Drivers.....	6
◆ Selecting Supply Voltage.....	6
7. Selecting Microstep Resolution and Output Current.....	6
◆ Microstep Resolution Selection.....	6
◆ Current Settings.....	6
◆ Standstill current setting.....	7

1. Introduction

◆ Introduction

The MC442 is a versatility fully digital stepping driver based on a DSP with advanced control algorithm. The MC442 is the next generation of digital stepping motor controls. It brings a unique level of system smoothness, providing optimum torque and nulls mid-range instability. The driven motors can run with much smaller noise, lower heating, smoother movement than most of the drivers in the markets. Its unique features make the MC442 an ideal solution for applications that require low-speed smoothness. Compared to the MC442, the MC442 makes the motor run into higher speed and the user can configure the standstill current in the software. What’s more, a pulse filter (smoother) has been built into the MC442.

◆ Features

- Supply voltage to +36 VDC;
- Output current programmable, from 0.71A to3A;
- Pulse input frequency;
- 15 selectable resolutions up to 25,600 steps/rev;
- TTL compatible and optically isolated input;
- Pure-sinusoidal current control technology;
- Self-adjustment technology;
- Support PUL/DIR;
- Short-voltage, over-voltage, over-current protections;
- Automatic idle-current reduction.

◆ Applications

Suitable for a wide range of stepping motors, from NEMA size 14 to 23. It can be used in various kinds of machines, such as X-Y tables, engraving machines, labeling machines, laser

cutters, pick-place devices, and so on. Particularly adapt to the applications desired with low noise, low heating, high speed and high precision.

2. Specifications

◆ Electrical Specifications (Tj = 25 °C/77 °F)

Parameters	Min	Typical	Max
Output current	0.71A		3.0 A
Supply voltage	+20VDC		+36VDC
Logic signal current	7mA	10 mA	16 mA
Pulse input frequency	0		300 kHz
Isolation resistance	500 M Ω		

◆ Operating Environment

Environment	Avoid dust, oil fog and corrosive gases
Ambient Temperature	0 °C — 50 °C
Humidity	40%RH — 90%RH
Operating Temperature	70 °C Max
Vibration	5.9m/s2 Max
Storage Temperature	-20 °C — 65 °C

◆ Installation specifications (unit: mm [inch])

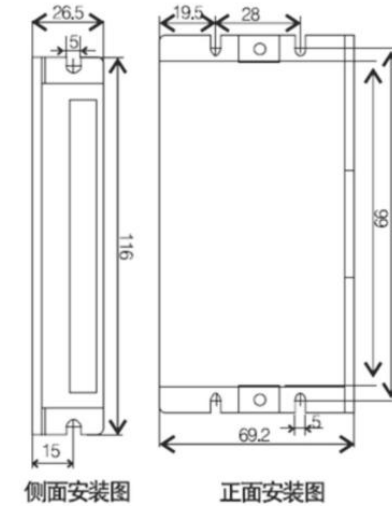

Figure 1: Installation specifications

◆ Elimination of Heat

- Driver's reliable working temperature should be <70 °C (158 °F), and motor working temperature should be <80 °C (176 °F);
- It is recommended to use automatic idle-current mode, namely current automatically reduce to 60% when motor stops, so as to reduce driver heating and motor heating;
- It is recommended to mount the driver vertically to maximize heat sink area. Use forced cooling method to cool the system if necessary.

3. External terminal instructions

◆ Control Signal Connector

Pin Function	Details

PUL+	Pulse signal: In single pulse (pulse/direction) mode, this input represents pulse signal, each rising or falling edge active; 4-5V when PUL-HIGH, 0-0.5V when PUL-LOW. For reliable response, pulse width should be longer than 1.5 μ s. Series connect resistors for current-limiting when +12V or +24V used. The same as DIR and ENA signals.
PUL-	
DIR+	DIR signal: In single-pulse mode, this signal has low/high voltage levels, representing two directions of For reliable motion response, DIR signal should be ahead of PUL signal by 5 μ s at least. 4-5V when DIR-HIGH, 0-0.5V when DIR-LOW. Please note that rotation direction is also related to motor-driver wiring match. Exchanging the connection of two wires for a coil to the driver will reverse motion direction.
DIR-	
ENA+	Enable signal: This signal is used for enabling/disabling the driver. High level (NPN control signal, PNP and Differential control signals are on the contrary, namely Low level for enabling.) for enabling the driver and low level for disabling the driver. Usually left UNCONNECTED (ENABLED).
ENA-	

◆ Main Circuit Connector

Pin Function	Details
+V	Power supply, 18~36VDC, Including voltage fluctuation and EMF voltage.
GND	Power Ground.
A+, A-	Motor Phase A
B+, B-	Motor Phase B

4. Control Signal Connector Interface

The MC442 can accept differential and single-ended inputs (including open-collector and PNP output). The MC442 has 3 optically isolated logic inputs which are located on connector P1 to accept line driver control signals. These inputs are isolated to minimize or eliminate electrical noises coupled onto the drive control signals. Recommend use line driver control signals to increase noise immunity of the driver in interference

environments. In the following figures, connections to open-collector and PNP signals are illustrated.

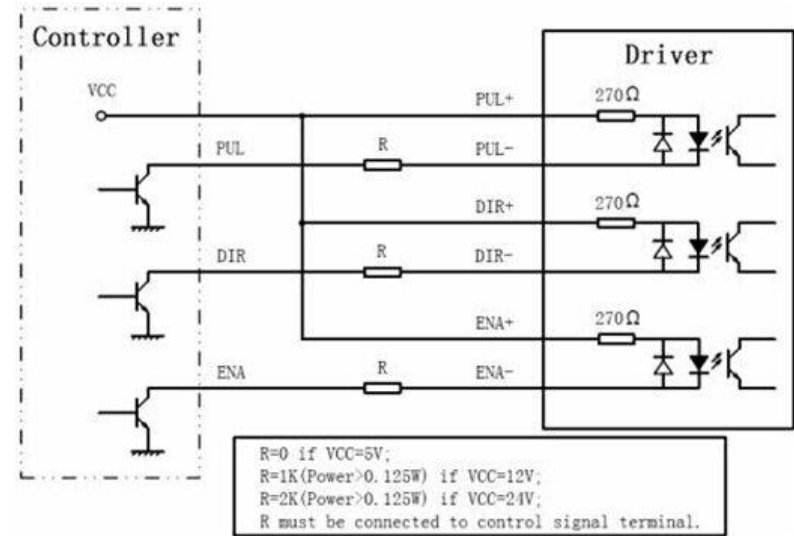

Figure 2: Connections to open-collector signal (common-anode)

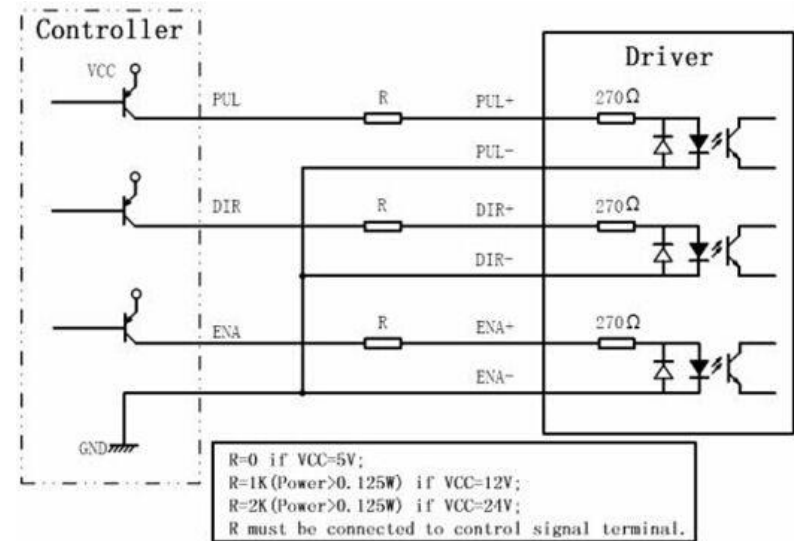

Figure 3: Connection to PNP signal (common-cathode)

◆ **Typical Connection**

A complete stepping system should include stepping motor, stepping driver, power supply and controller (pulse generator). A typical connection is shown as figure 4.

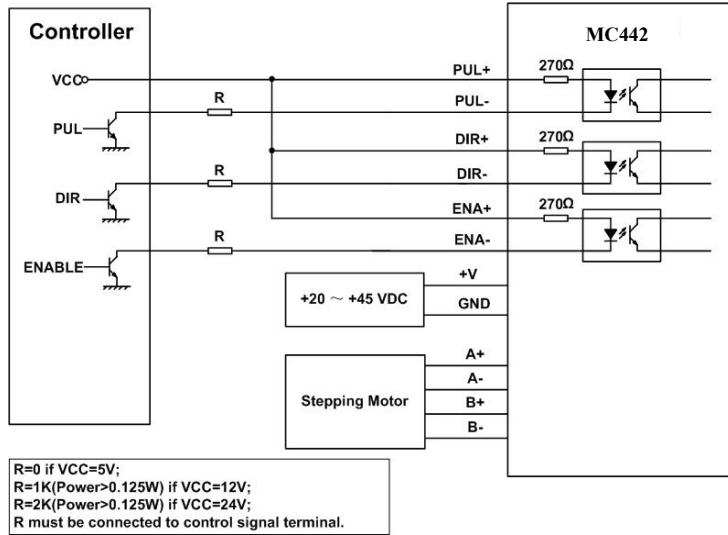

Figure 4: Typical connection

◆ **Sequence Chart of Control Signals**

In order to avoid some fault operations and deviations, PUL, DIR and ENA should abide by some rules, shown as following diagram:

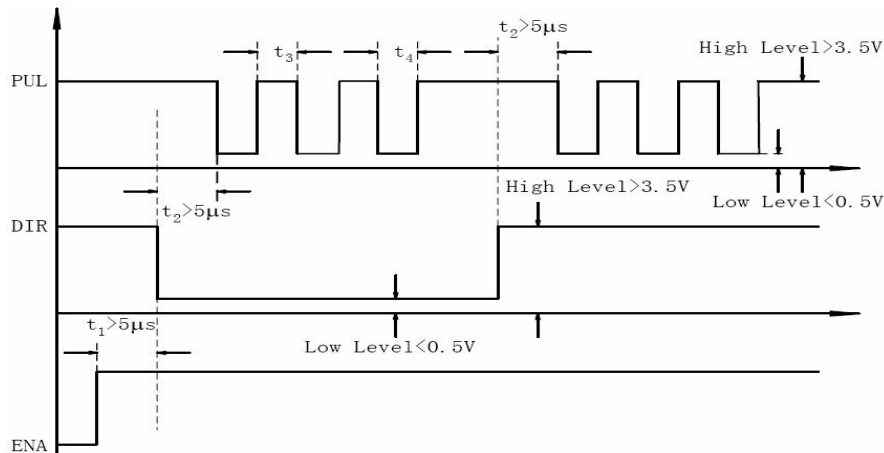

Figure 5: Sequence chart of control signals

Remark:

- t1: ENA must be ahead of DIR by at least 5 s. Usually, ENA+ and ENA- are NC (not connected). See “Connector P1 Configurations” for more information.
- t2: DIR must be ahead of PUL effective edge by 5 s to ensure correct direction;
- t3: Pulse width not less than 1.5 s;
- t4: Low level width not less than 1.5 s.

4. Connecting the Motor

The M442 can drive any 2-phase and 4-phase hybrid stepping motors.

◆ **Connections to 4-lead Motors**

4 lead motors are the least flexible but easiest to wire. Speed and torque will depend on winding inductance. In setting the driver output current, multiply the specified phase current by 1.4 to determine the peak output current.

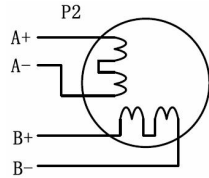

Figure 6: 4-lead Motor Connections

◆ **Connections to 8-lead Motors**

8 lead motors offer a high degree of flexibility to the system designer in that they may be connected in series or parallel, thus satisfying a wide range of applications.

• **Series Connections**

A series motor configuration would typically be used in applications where a higher torque at lower speeds is required. Because this configuration has the most inductance, the performance will start to degrade at higher speeds. In series mode, the motors should also be run at only 70% of their rated current to prevent over heating.

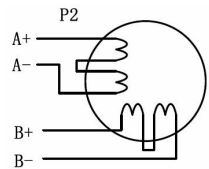

Figure 7: 8-lead motor series connections

• **Parallel Connections**

An 8 lead motor in a parallel configuration offers a more stable, but lower torque at lower speeds. But because of the lower inductance, there will be higher torque at higher speeds. Multiply the per phase (or unipolar) current rating by 1.96, or the bipolar current rating by 1.4, to determine the peak output current.

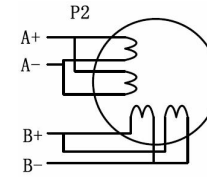

Figure 8: 8-lead motor parallel connections

5. Power Supply Selection

The MC442 can match medium and small size stepping motors (from NEMA frame size 14 to 23) made by Lichuan or other motor manufactures around the world. To achieve good driving performances, it is important to select supply voltage and output current properly. Generally speaking, supply voltage determines the high speed performance of the motor, while output current determines the output torque of the driven motor (particularly at lower speed). Higher supply voltage will allow higher motor speed to be achieved, at the price of more noise and heating. If the motion speed requirement is low, it's better to use lower supply voltage to decrease noise, heating and improve reliability.

◆ **Regulated or Unregulated Power Supply**

Both regulated and unregulated power supplies can be used to supply the driver. However, unregulated power supplies are preferred due to their ability to withstand current surge. If regulated power supplies (such as most switching supplies.) are indeed used, it is important to have large current output rating to avoid problems like current clamp, for example using 4A supply for 3A motor-driver operation. On the other hand, if unregulated supply is used, one may use a power supply of lower current rating than that of motor (typically 50%~70% of motor current). The reason is that the driver draws current from the power supply capacitor of the unregulated supply only during the ON

duration of the PWM cycle, but not during the OFF duration. Therefore, the average current withdrawn from power supply is considerably less than motor current. For example, two 3A motors can be well supplied by one power supply of 4A rating.

◆ **Multiple Drivers**

It is recommended to have multiple drivers to share one power supply to reduce cost, if the supply has enough capacity. To avoid cross interference, DO NOT daisy-chain the power supply input pins of the drivers. (Instead, please connect them to power supply separately.)

◆ **Selecting Supply Voltage**

The power MOSFETS inside the M442 can actually operate within +20 ~ +36VDC, including power input fluctuation and back EMF voltage generated by motor coils during motor shaft deceleration. Higher supply voltage can increase motor torque at higher speeds, thus helpful for avoiding losing steps. However, higher voltage may cause bigger motor vibration at lower speed, and it may also cause over-voltage protection or even driver damage. Therefore, it is suggested to choose only sufficiently high supply voltage for intended applications, and it is suggested to use power supplies with theoretical output voltage of +20 ~ +36VDC, leaving room for power fluctuation and back-EMF.

6. Selecting Microstep Resolution and Output Current

This driver uses an 8-bit DIP switch to set microstep resolution, and motor operating current, as shown below:

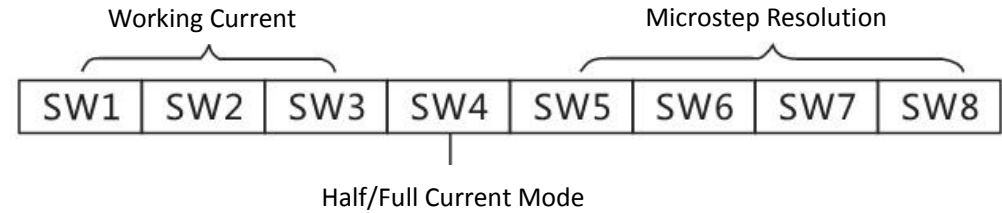

◆ **Microstep Resolution Selection**

Microstep resolution is set by SW5, 6, 7, 8 of the DIP switch as shown in the following table:

Microstep	Steps/rev.(for 1.8° motor)	SW5	SW6	SW7	SW8
2	400	OFF	ON	ON	ON
4	800	ON	OFF	ON	ON
8	1600	OFF	OFF	ON	ON
16	3200	ON	ON	OFF	ON
32	6400	OFF	ON	OFF	ON
64	12800	ON	OFF	OFF	ON
128	25600	OFF	OFF	OFF	ON
5	1000	ON	ON	ON	OFF
10	2000	OFF	ON	ON	OFF
20	4000	ON	OFF	ON	OFF
25	5000	OFF	OFF	ON	OFF
40	8000	ON	ON	OFF	OFF
50	10000	OFF	ON	OFF	OFF
100	20000	ON	OFF	OFF	OFF
125	25000	OFF	OFF	OFF	OFF

◆ **Current Settings**

For a given motor, higher driver current will make the motor to output more torque, but at the same time causes more heating in the motor and driver. Therefore, output current

is generally set to be such that the motor will not overheat for long time operation. Since parallel and serial connections of motor coils will significantly change resulting inductance and resistance, it is therefore important to set driver output current depending on motor phase current, motor leads and connection methods. Phase current rating supplied by motor manufacturer is important in selecting driver current, however the selection also depends on leads and connections.

The first three bits (SW1, 2, 3) of the DIP switch are used to set the dynamic current.

Select a setting closest to your motor's required current.

Peak Current	RMS Current	SW1	SW2	SW3
1.00A	0.71A	ON	ON	ON
1.46A	1.04A	OFF	ON	ON
1.91A	1.36A	ON	OFF	ON
2.37A	1.69A	OFF	OFF	ON
2.84A	2.03A	ON	ON	OFF
3.31A	2.36A	OFF	ON	OFF
3.76A	2.69A	ON	OFF	OFF
4.20A	3.00A	OFF	OFF	OFF

Notes: Due to motor inductance, the actual current in the coil may be smaller than the dynamic current setting, particularly under high speed condition.

◆ **Standstill current setting**

SW4 is used for this purpose. OFF meaning that the standstill current is set to be half of the selected dynamic current, and ON meaning that standstill current is set to be the same as the selected dynamic current.

The current automatically reduced to 60% of the selected dynamic current one second after the last pulse. Theoretically, this will reduce motor heating to 36% (due to $P=I^2 \cdot R$) of the original value. If the application needs a different standstill current, please contact Lichuan.